

FlexHammer™ FH 1800 Mobile



Solutions for industrial recycling

Solutions in waste handling

IQR FlexHammer™ 1800 Mobile Unit



Multi purpose heavy duty hammermill

- » Outstanding performance with 30 years of built-in experience.
- » The FlexHammer™ system presents great flexibility regarding variation in feed materials.
- » Swedish quality.

WELL KNOWN FOR IT'S UNBEATEN CAPACITY AND FLEXIBILITY.

The FH1800 Mobile Unit is a well known all purpose, heavy duty, high capacity hammermill of industrial quality standard.

Typical feed materials:

- » Wood waste e.g. demolition timber, railway sleepers, treetops and branches, bark, offcuts from industries etc.
- » Household waste.
- » Industrial waste of different kinds.
- » Commercial waste, packing materials.

Finished products:

Are being used as fuel for energy production or for compost or just for volume reduction.

Particle size of finished products:

The hammermill's design allows for a large variety of the finished products' particle size. Typical finished products are e.g. between 0-50, 0-100 and 0-250 mm.

Contaminations:

The hammermill has a mechanical safety device in form of a reject door which opens in case of pressure from uncrushable objects. Stones will be crushed.

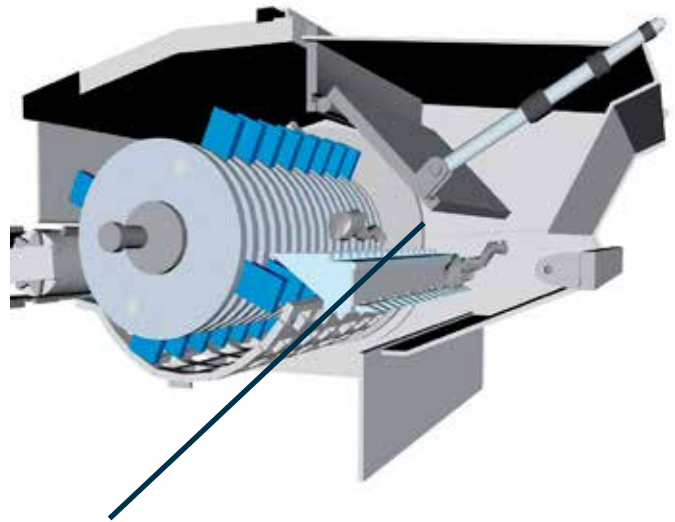

FlexRejectDoor™

This is a safety device which protects the mill from damage and stoppages if any uncrushable material is fed in by mistake.

DATA

Dimensions transport L/W/H	12,7 / 3,1 / 4,2
Total weight:	~47,5 ton (30 km) ~45 ton (80 km)
Feed opening dimensions, width / height	1,8 m / 0,8 m
Feedroller diameter:	0,8 m
Feeder	5,5 / 1,8 (9m3)
Rotor weight	~5 tons
No. of hammers / Weight of hammer	48 pcs / 11kg
Rotor diameter/tip to tip	1200 mm
Speed of rotor:	~900 rpm
Engine:	Cat C27 stage 5 Tier 4 Final
Enginepower:	875 hp - 1200 hp
Magnet type:	Elme permanent cross belt magnet
Endmagnet in drivedrum	Yes
Discharge belt width	1,4 m
Discharge belt - dropping height	4,5 m





Solutions for industrial recycling

Headquarter, Trollhättan

Postal and delivery address

IQR Systems AB
Stallbackavägen 26
461 38 Trollhättan
Sweden





Phone & E-mail

Office: +46 520-48 58 80
info@iqr.se

Online

Webb & social media

www.iqr.se

 @IQRsystems
 @IQRsystems
 IQRsystems
 IQRsystems